

(12) **EUROPEAN PATENT APPLICATION**

(21) Application number: 85307890.5

(61) Int. Cl.⁴: **G 01 N 27/30**
G 01 N 27/28, G 01 N 27/56

(22) Date of filing: 31.10.85

(30) Priority: 31.10.84 GB 8427559
 15.10.85 GB 8525326

(43) Date of publication of application:
 02.07.86 Bulletin 86/27

(84) Designated Contracting States:
 AT BE CH DE FR GB IT LI NL SE

(71) Applicant: UNILEVER PLC
 Unilever House Blackfriars P.O. Box 68
 London EC4P 4BQ(GB)

(84) Designated Contracting States:
 GB

(71) Applicant: UNILEVER NV
 Burgemeester s'Jacobplein 1 P.O. Box 760
 NL-3000 DK Rotterdam(NL)

(84) Designated Contracting States:
 BE CH DE FR IT LI NL SE AT

(72) Inventor: Nylander, Claes Ivan
 8 Colworth Road
 Sharnbrook Bedfordshire MK44 1ET(GB)

(72) Inventor: Birch, Brian Jeffrey
 14 Duchy Close
 Chelveston Northants MK44 1SG(GB)

(72) Inventor: Marshman, Clive Edward
 37 Wood End Lane
 Pertenhall Bedfordshire MK44 2AS(GB)

(72) Inventor: Stephenson, Peter Richard
 4 The Barn
 Felpersham Bedfordshire MK43 7JF(GB)

(74) Representative: Standliffe, Terence Christopher et al.
 UNILEVER PLC Patents Division P.O. Box 68 Unilever
 House
 London EC4P 4BQ(GB)

(54) Apparatus for use in electrical, e.g. electrochemical, measurement procedures, and its production and use and composite assemblies incorporating the apparatus.

(57) A composite electrode, comprising: a solid non-metallic substrate, (such as ceramic, glass, or epoxy resin,) and, bonded directly or indirectly to said substrate, a non-conducting matrix, incorporating particles which are accessible to the electrode surface and contain an insoluble metal salt (e.g. halide) in direct electrical contact with the metal corresponding to said salt, said metal being present either (i) in the form of metallic particles incorporated in a non-conducting matrix zone disposed so that said metal salt-containing particles are located between said metallic particles and said electrode surface, and/or (ii) a solid metallic surface in the form of an intermediate layer between said matrix and said substrate.

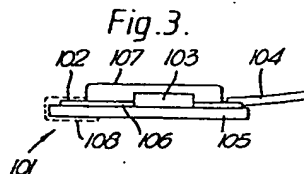

Apparatus for use in electrical, e.g. electrochemical, measurement procedures, and its production and use, and composite assemblies incorporating the apparatus

5 This invention relates to apparatus suitable for use in electrical, e.g. electrochemical, measurement procedures, and to its production and use.

10 It is known for various electrical (especially electrochemical) measurement purposes to make and use ionophore-sensitised polyvinylchloride membranes. Known ion-selective polyvinylchloride membrane electrodes include for example constructions in which an electrode is separated from an ionophore-loaded polymer by an
15 intermediate inner electrolyte. One such known pvc-containing ionselective electrode system comprises a solid hollow tube containing an aqueous electrolyte solution. The end of the tube is closed by an ion-selective pvc membrane secured by a screw-down compression
20 fitting. The inner electrolyte normally contains chloride together with (if different) a salt of an ion to which the electrode system has been made sensitive by the use of a membrane of appropriate selectivity, and the inner

electrolyte has immersed in it a silver/silver chloride electrode. The silver is provided with a connection to an external circuit, usually an electrometer amplifier of high impedance, connected via a length of screened flexible cord. Normally, such an electrode is in use immersed in a (e.g. dilute) aqueous solution relevant to the measurement purpose, as part of a cell of which the other side is completed by a standard-potential reference electrode, e.g. one comprising silver/silver chloride in high concentration KCl solution, e.g. 3M KCl. The pvc of the membrane normally contains plasticiser and ionophore to enable the electrode system to be sensitive to a particular component of the analyte liquid. Also known is the use of coated-wire electrodes based on ionophore-loaded polyvinylchloride coatings over conductive metal wire or graphite rod. We consider that for several purposes these coated-wire arrangements are rather unstable, e.g. in several examples their lifetime is limited by failure of the polymer layers to retain their adhesion to the solid conductor, and they are sometimes awkward to make. The electrode systems containing inner electrolyte are rather complex in construction. These systems can also often be insufficiently robust.

Prior art in relation to the preparation of electrode materials also includes for example GB 2 021 772 (preparation and heat-treatment of mixtures of silver and silver particles in porous epoxy applied to metal substrate) and GB 1 586 691 (potted assemblies of integrated circuits and button electrodes made by loosely sintering powdered glass and silver compounds, and backing the sinter with a pourable polymer compound), as well as the application of electroactive particles in matrices of polymer directly to metal electrodes, or as outer membranes in electrodes which comprise inner electrolyte.

One of the aims of this invention is to produce electrodes of robust construction without inner electrolyte, and to achieve mechanical stability, freedom from liability to develop air bubbles (in an inner electrolyte liquid) and freedom from concentration changes over time.

According to the present invention we provide a composite electrode, comprising;

10

a solid non-metallic substrate, (such as ceramic, glass or plastics material, e.g., epoxy resin)

and bonded directly or indirectly to said substrate,

15

a non-conducting matrix, incorporating particles which are accessible to the electrode surface and contain an insoluble metal salt (e.g. halide) in direct electrical contact with the metal corresponding to said salt, said metal being present either (i) in the form of metallic particles incorporated in a non-conducting matrix zone disposed so that said metal salt-containing particles are located between said metallic particles and said electrode surface, and/or (ii) a solid metallic surface in the form of an intermediate layer between said matrix and said substrate.

20

25

We find that electrodes of this form offer robustness, versatility of application and convenience in use. A number of embodiments are described below. In many of them, the electrode has an electroactive membrane which overlies said matrix incorporating said metal halide-containing particles. In the description given below, references to ionophores mean materials such as ion carriers which are capable of conferring electrochemical selectivity on such electroactive membranes, without

30

35

regard to other particular physicochemical properties of such ionophores, e.g. their electrical charge or neutrality.

5 In certain examples, the metal halide-containing particles present are metallic particles derived from a layer of non-conducting matrix incorporating metallic particles, the surface of which layer has been treated to convert metal to metal halide, e.g. produced by anodic
10 electrolysis of the metal.

In several useful forms of the electrodes, the particle-containing matrix has been formed by printing a layer of corresponding material in flowable form on to the
15 solid substrate, and hardening of layer or allowing it to harden.

Suitable substrates comprise for example epoxy, polyvinylchloride, or alumina or other ceramic material.

20 The number of layers is not limited to two: for example successively applied adjacent matrix layers can be present on the substrate, including a layer containing metallic particles and a further layer containing
25 insoluble metal-salt-containing particles.

It is especially useful to place a hermetic sealing layer over all conductive or electroactive parts of the electrode other than the sensitive surface intended to
30 contact electrolyte.

Also provided by the invention is an assembly comprising a composite electrode as described herein, wherein the metallic part of the composite electrode is
35 functionally connected to a hermetically sealed (packaged) integrated semiconductor signal processor or impedance

converter circuit mounted on said solid non-metallic substrate.

5 For example, there can be present an alumina or other ceramic substrate, or a pvc or other polymer substrate, on which there is mounted a hermetically encapsulated integrated circuit, with its connexions electrically bonded to the conductor(s) forming electrode(s) on the substrate, the structure being further encapsulated with a
10 hermetic sealing material applied by spraying, dip-coating, moulding or otherwise in manner known per se, the sealing material being for example epoxy material or pvc or other polymer, to form an integral sealed assembly having a functionally exposed electrode or electrode area
15 or areas not covered by the final encapsulation treatment.

Also provided by the invention is a process for producing these composite electrodes, which comprises (i) applying to a solid non-conducting substrate surface a
20 flowable layer of a matrix material comprising particles that contain an insoluble metal and/or metal salt (e.g. halide), (ii) allowing the layer to harden and bond to the substrate surface, and (iii) (where the particles contained metal but did not already contain insoluble
25 metal salt) forming insoluble metal salt corresponding to the metal of the particles either by treatment of the surface of said particle-containing matrix layer to form superficial insoluble metal salt thereon, or by applying a further bonded matrix layer of particles containing
30 corresponding metal salt.

Further details and embodiments of the invention are given hereinbelow.

35 In the performance of the present invention, the non-conducting matrix can be a body of polymer such as

polyvinyl chloride, which incorporates conductive particles. The conductive particles are such as to allow the provision of a conductive connection from the particle-containing composite to an external electrical circuit. In an example to be described below, the conductive particles provide the composite electrode with a conductivity corresponding to resistivity of a few milliohm-cm. This value is by no means critical: resistivities several orders of magnitude higher can be used, but the resistance of the electrode material should generally be small in comparison with that of the external circuit (often many megohms).

Besides polyvinylchloride, other useful nonconducting solid matrices are for example polyurethane, polystyrene, polyvinylacetate, e.g. mixtures of pvc and polyvinylacetate, as well as inorganic matrices e.g. such as glass. In what follows, mention of polyvinylchloride (pvc) implies also the possible use of any such substitute matrix material. In the structures provided by the invention, the conductive particles can be for example graphite, silver, platinum, palladium-silver, tin-palladium-silver, gold, or copper. If desired, the matrix in which the particles are incorporated can be an organic matrix derived by solidification from the paint vehicle used as the base of conductive paints known and available for use in thick-film microcircuit manufacture, e.g. for the purpose of painting or screen-printing conductive tracks on flat insulating substrates such as ceramic substrates. Suitable particle sizes for the conductive particulates are for example those in the range from (of the order of) 20 to (of the order of) 200 microns. Suitable levels of incorporation of the particles into the composite can include for example those of the order of 10%-80%, e.g. 50%, by volume (based on the volume of the composition), or, dependent on the nature of

the particles, whatever level is needed to reach a desired degree of electrical conductivity. One example of an electrode structure comprising silver-pvc has 3:1 silver particles: pvc particles by weight, with 50 micron (maximum particle size) silver particles.

Thus, one form of the composite electrode comprises a conductor and a non-conductive membrane matrix material, (e.g. glass or organic polymer), in direct contact with the conductor, wherein the conductor comprises a matrix incorporating conductive particles (containing metal salt, e.g. silver chloride or silver/silver chloride particles), and the overlying organic membrane material, if present, comprises a sensitising component such as an ionophore, for sensitising the electrode to a particular analyte to be investigated, and the organic membrane material is securely bonded to the matrix of the conductive composite. For example, the membrane material and the matrix can, conveniently, both be of a similar polymer and can be fused or bonded together in any convenient manner. The conductor can be for example in the form of a conductive metal track or film fixed to a plastics or ceramic substrate.

In these arrangements, usually the intermediate metal layer is smaller in area than the substrate and the matrix, and there is direct bonding between the substrate and the matrix, as well as between the matrix and the metal.

This structure is particularly robust and for example can give longer life in use than a comparable (e.g. coated-wire) electrode.

It is particularly useful and within the scope of the invention to provide electrode structures comprising a

composite layered structure of pvc comprising a layer or zone of pvc incorporating conductive particles, as mentioned above, and a layer or zone of pvc incorporating an ionophore, to form a membrane that in use separates the
5 conductive pvc composition from an external liquid of which an electrochemical characteristic is to be measured or tested. Preferably the same polymer is used as basis for the particle-loaded layer as for the ionophore-loaded layer. This has been found to facilitate fusion and high
10 bond strength between the layers. We find that such arrangements are highly useful in that amongst other things they combine freedom from inner electrolyte and from liquid junctions, with good and robust stability.

15 For the purposes of these composite layered structures it is preferred (for the pvc of the zone that incorporates the conductive particles) to use pvc incorporating either no plasticiser or only very small quantities of plasticiser, (described herein as "pure"
20 pvc). (Preferably, of the order of 10% by weight of plasticiser or less can be present in this zone. Preferably there is less, e.g. <5%, e.g. <1%).

In the case of the membrane material, examples of
25 suitable contents for the ionophore or other sensitising component are for example within the range 5-10% by weight of the whole membrane composition. The ionophore-containing zone can be for example 0.1-mm thick. The pvc of the zone that incorporates the
30 ionophore or other sensitising component should usually incorporate conventional relatively large amounts of plasticiser, as used in previous ionophore-pvc membranes, e.g. the ionophore-containing layer can for example be composed largely of a pvc:plasticiser composition in
35 proportions for example in the range 1:1 to 1:2 by weight. Examples of plasticisers useful in connexion with

ion-selective polymer membranes, especially pvc membranes, include dioctyl phenyl phosphonate, diethyl adipate, dioctyl sebacate, trioctyl phosphate, and o-nitrophenyl phenyl ether. Examples of useful ionophores include
5 calcium diisooctyl phenyl phosphate (for calcium-sensitive electrodes) valinomycin (for potassium-sensitive electrodes), tridodecylamine (for hydrogen-ion-sensitive electrodes), particles of silver chloride, bromide, or
10 iodide (for corresponding halide-sensitive electrodes), particles of silver sulphide (for sulphide-sensitive electrodes), mixtures of particles of silver and copper sulphides (for electrodes sensitive to copper as well as to sulphide), and more generally a finely divided
15 particulate form of any of the materials previously used in crystalline form for making single-crystal electrodes, can be incorporated into the polymer or other non-conducting matrix of the electrode membrane, in sufficient amount to put the particles in electrically
20 effective contact to enable the electrode to respond to the presence of the corresponding constituent of the surrounding solution to be tested or measured.

Particularly useful examples of the electrodes
25 comprise a metallic conductor in contact with an insoluble salt of a metal comprised in the conductor: e.g. silver and silver halide. It is for example particularly useful; in cases where the specific electrode material is based on inorganic ion-sensitive materials, to provide an electrode
30 structure with one or a plurality of junctions between pairs of active materials, each pair having an anionic or cationic component in common, and the material in contact with the analyte solution having a common component with the analyte. For example, silver and silver halide have a
35 common cationic component, (i.e. silver, notwithstanding that the silver of the metallic conductor is substantially

not in the cationic form), and a suitable combination of materials for a fluoride-sensitive electrode is for example a multilayered, e.g. 4-layered, (e.g. laminate) construction, each layer comprising particles of the following materials in a (e.g. pvc) matrix: silver, silver chloride, silver fluoride, lanthanum fluoride.

To manufacture these structures it can be convenient and is within the scope of the invention to build up successive layers of matrix such as polyvinylchloride, loaded with various additives, e.g. as follows. If desired, there can be provided a zone of pure (i.e. tolerably plasticiser-free) pvc. Either as an overlying layer, or as a substrate in itself, there can be provided a zone of silver-particle-loaded (pure) pvc. This zone can be treated to give it a content of silver chloride accessible at its surface and in conductive contact with the useful conductive structure (e.g. as described in the Examples below). Alternatively, a further zone comprising pvc loaded with silver chloride particles, can be provided with equivalent effect. After treatment to provide silver chloride, a further zone (layer) of plasticised pvc loaded with ionophore or other sensitising component can be provided, to act as an electroactive membrane. The successive zones can be deposited either by solidification of applied (thin) layers of molten (thermoplastic) pvc with suitable additives, or by evaporation of solvent from suitably-loaded pvc solutions in a compatible solvent such as tetrahydrofuran, which can be applied by any suitable technique chosen from among those known per se, such as dip-coating, printing, etc.

It is within the scope of the invention to apply the electroactive membranes in any suitable way, not only by forming a membrane which has an ionophore content but also by forming a membrane without such a content and then

contacting the membrane so formed with an ionophore to allow the latter to activate the membrane, (e.g. as described by E. Fogt and P.Cahalan in Anal. Chem. (1985) 57, pp 1155-1157, and in USP 4 486 290).

5

In order to confer structural strength on the composite there can be a substantial core, e.g. a rod or tube or a flat substrate, of pvc or other (e.g. polymer) matrix material, e.g. pvc of normal commercial grade, which can incorporate substantial quantities of plasticiser, which has successive and preferably thin layers built up on it as follows:- (a) (optionally) pure pvc if desired, (b) silver-particle-loaded pure pvc, and (c) ionophore-loaded or otherwise sensitised plasticised pvc. The layers can in certain useful examples be of the order of 0.1-1mm thick in each case.

In one highly important configuration, for example, a planar substrate of material to which the pvc layers can be bonded or fused can have successive analogous flat layers built upon it, the successive layers for example comprising compositions as described above and forming an integral fused or bonded structure.

It is understood that when a chloriding process is required, the chloriding can be applied to silver as used in embodiments of this invention, by any method known per se, e.g. electrolysis with the electrode placed as anode in an electrolytic HCl bath, or other known way. Alternatively the chloride may be applied as a layer of matrix incorporating silver chloride particles.

The use of pure (plasticiser-free) pvc or other non-conductive (e.g. polymer) matrix as an encapsulation material and/or structural support material for an electrode structure incorporating an ionophore-loaded or

otherwise ion-selectively sensitised membrane fused or bonded to the substrate is believed to be an independently novel and advantageous feature of the invention in itself and in combination with any of the features described
5 elsewhere in this specification.

The manufacture of structures according to embodiments of this invention can be carried out by using a solvent-welding or solvent-casting technique, or other
10 technique e.g. a thermal technique to insure that the layers involved in the composites are in intimate contact and preferably become or are formed into an integral, one-piece fused or bonded construction. Fusion or annealing processes are for example particularly suitable
15 for vitreous or ceramic constructions, e.g. a glassy matrix containing ion-selective inclusions such as particles can be fused on to a glassy or ceramic substrate, e.g. containing conductive inclusions such as conductive particles.

20 The nature and variety of ion-selective membranes, known per se, which can be fabricated to form parts of composite structures that constitute embodiments of the present invention, is very wide, and depends on the
25 particular end-use to which the electrode is to be put. Specifically incorporated by reference herein are all the detailed membrane electrode compositions described (in connexion with conventional wire cores) by G J Moody and J D R Thomas in "Poly(Vinyl Chloride) Matrix Membrane
30 Ion-Selective Electrodes", ch.4 of "Ion Selective Electrodes in Analytical Chemistry", ed. H Freiser, Plenum Press 1980, and in U Fiedler and J Ruzicka, Anal. Chim. Acta, 67, 179 (1973).

35 Further details of membrane fabrication, also incorporated herein by reference, are given by H Tamura et

al; Anal. Chem. (1982), 54, pp1224-1227, and by D. Ammann et al., in "Ion Selective Electrode Reviews", 5 (1), 1983, pp 3 et seq.

5 According to another aspect of this invention, an electrode structure based on a non-conducting matrix also comprises a hermetically sealed signal processor circuit functionally connected to the (one or plurality of) electrodes of the electrode structure, said hermetically
10 sealed signal processor circuit comprising a hermetically sealed (packaged) integrated circuit together with ancillary conductive connections and possibly further components mounted together on the non-conducting matrix and provided with overall hermetic sealing.

15 The electrode or electrodes can in themselves for example (but without limitation) take any of the forms described above in this specification or in the succeeding description and Examples.

20 The hermetically sealed package including the electronic circuit can be used directly as the non-conducting substrate mentioned earlier or the package can be mounted onto the substrate used for the electrode.

25 By using these forms of construction, composite devices for electrochemical measurements can easily be made for example by printing conductors (e.g. using conductive particles in an organic matrix vehicle) on to
30 an alumina or other ceramic substrate, or on to a pvc or other polymer substrate, mounting a hermetically encapsulated integrated circuit on the substrate and electrically bonding its connexions to the conductors, forming the electrode(s) on the substrate, and further
35 encapsulating the substrate by spraying, dip-coating, moulding or otherwise applying in manner known per se a

hermetic sealing and insulating encapsulant such as epoxy material or pvc or other polymer, to form an integral sealed assembly having a functionally exposed electrode or electrode area or areas not covered by the final
5 insulating encapsulation treatment.

There are a number of different standard packages for integrated circuits. Examples of such packages which are particularly useful for this purpose are DIL
10 (dual-in-line), SO (small outline) and LCC (leadless chip carrier).

Many integrated circuits are commercially available in DIL and SO packages. The use of these in the present
15 invention is therefore an easy and inexpensive option. The advantage with LCC is that non-standard circuits are easily mounted into these.

It is also possible to mount an integrated circuit
20 directly onto the substrate but this is not very practical. The reason is that this puts very severe restrictions on the insulation of the assembly. Moreover, the extreme delicacy of the very thin bonding wires (typically 25 μm) which are used for this purpose makes it
25 difficult to encapsulate the assembly properly without damaging these wires.

By using pre-packed electronic circuits the assembly becomes mechanically robust and can therefore be
30 encapsulated by a variety of means.

Preferably the outer material of the electrode or electrode area(s) (e.g. polymer membrane) is chosen for bonding compatibility with the hermetic sealant applied to
35 the remaining parts of the assembly so that no ingress of

water or corrosive contaminants such as ions in solution can occur to degrade the electrical connections within.

5 The details of the circuitry forming part of these composite assemblies are in themselves of known kind and form per se no part of this invention: but by way of illustration it can be pointed out that standard semiconductor devices or integrated circuits, e.g. operational amplifier integrated circuits, especially those with 10 f.e.t. inputs, or simply single encapsulated f.e.t.'s, are very suitable for inclusion in the hybrid electrode assemblies described herein.

15 Examples of embodiments of the invention and their manufacture and use are illustrated in greater detail by the following description and accompanying drawings.

Example 1

20 A chloride-sensitive electrode can be made and used as follows. A rod of pvc of ordinary commercially available grade is dipped and stirred a few minutes in tetrahydrofuran (THF) to round its sharp edges and leave a partly dissolved surface layer to fuse with the additional 25 material to be applied. The rod so treated is then dipped in a solution of pvc and trioctyl phosphate plasticiser containing suspended powdered silver, in THF (proportions 0.05g pvc, 0.01g plasticiser, and 0.3g silver per ml mixture), and air-dried at about 50°C for about 30 minutes 30 to evaporate the solvent.

The composite electrode so made is given an ohmic contact at one end and chlorided by anodization, for example in 0.1M HCl solution opposite a platinum cathode 35 at a current density of about 300 microamps per cm² of silver composite electrode surface for about half an hour.

The anodized electrode, now with a surface content of silver chloride, is rinsed and stored in purified (deionised) water preferably at least 24 hours before use. The electrode can be used in a similar manner as a conventional silver/silver chloride electrode.

Example 2

A calcium-selective planar electrode structure can be made and used as follows, and is illustrated in diagrammatic plan and section in Figures 1 and 2.

A laminar plastics substrate 1 in the form of for example a 5mm x 30mm strip, 0.5mm thick, of mixed polyvinylchloride/polyvinylacetate with filler, and a relatively low content of plasticiser, has its surface partly masked off by a solvent-resisting mask to leave an area to which an conductive strip 2 is applied as follows. The area to be treated is wetted with THF, and a silver-powder-containing pvc-plasticiser-solvent mixture as in Example 1 is applied in an amount sufficient to give 0.1-0.2 mm thickness in the conductive strip 2 after air-drying as in Example 1. The masking is removed before the air-drying, and the dry product is anodized and stored as described in Example 1. After storage for 24 hours the composite is air-dried again, slightly wetted with THF, and an ion-selective pvc membrane 3 is applied by dipping one end of the composite into a mixture of the following components dissolved or dispersed in THF: 0.03 g/ml pvc, 0.06 g/ml dioctyl phenylphosphonate plasticiser, and 0.0067 g/ml di-(4(1,1,3,3,-tetramethylbutyl) phenyl) ionophore. After one dip in this mixture the composite is air-dried for about an hour to remove the solvent and form the membrane 3. The electrode is then masked off at each end and dipped to form a further coating 4 of slightly plasticised pvc about the middle of the strip. The

coating 4 partly overlaps the membrane 3 previously formed and leaves a bare extremity of the strip at the other end, and is formed by dipping or otherwise contacting the desired part of the strip in a solution of 0.1g/ml pvc and 5 0.01 g/ml trioctylphosphate in THF, followed by air-drying about 2 hours at about 30°C. Coating 4 is an effective insulator and overlaps membrane 3 by about 5mm. An ohmic contact 5 is formed at the bare extremity of conductive strip 2 by any convenient method; the contact can be 10 retained by a clip or by using silver-epoxy glue or by low-temperature soldering.

The resulting electrode is useful as a robust calcium-sensitive electrode.

15

Example 3

In a particularly preferred embodiment, 20 potassium-selective electrodes can be reproducibly produced in large numbers by the following method. Cut out 20 cm x 20 cm sheets from a 1.5 mm thick sheet of PVC (e.g. Davcron, ICI) and screen-print thereon 1.5 mm wide and 13 μ m thick parallel tracks, 5 mm apart, of silver 25 particle loaded polymer paste (e.g. P230, Johnson Matthey) through a suitable silk-screen. Cure the printed paste in an oven at 50°C for 12 hours. Divide the sheets into four parts, 20 cm x 5 cm, by cutting them across the printed tracks. Chloridise the surface of the tracks by 30 immersing the sheets in a water solution of 3% hydrogen peroxide and 0.1 molar hydrochloric acid so that about 2 cm of each track is kept above the solution. After 5 minutes a suitable amount of silver chloride will have formed on the surface of the immersed part of the tracks. 35 Remove the sheets from the solution and rinse well in

distilled water. Leave the electrodes to dry for at least one hour in a dry and clean atmosphere.

5 If the electrodes are to be stored before the chloridising treatment described above they should be kept in a dry atmosphere free from hydrogen sulphide to prevent uncontrolled formation of silver sulphide on the surface. This atmosphere can be obtained in a closed cabinet containing silica gel and sodium hydroxide pellets.

10 Cast ion selective membranes onto the chloridised part of the electrodes by immersing the sheets in the same manner as above in a solution of 28 mg/ml PVC and 55 mg/ml dioctyl phthalate and 0.8 mg/ml valinomycin in 15 tetrahydrofuran. The sheets should be immersed in this solution for only a few seconds and slowly withdrawn from the solution. Leave the sheets to dry for about 5 minutes and repeat this procedure ten times. Thereafter, store the sheets in a dry atmosphere at 25°C for one hour 20 to allow the solvent to evaporate.

Cut the sheets between the tracks to produce individual devices of dimensions 50 mm x 5 mm. An electric lead can be connected to the uncoated end of each 25 electrode by means of, for example, a suitable silver loaded epoxy resin, and the uncoated end and the lead can be encapsulated by any suitable means.

30 The resulting electrodes can be used in the same way as conventional ion selective electrodes for the analysis of potassium ions in aqueous solutions.

35 The electrode fabrication methods employed in the preceding description and examples can also be applied to the construction of further embodiments within the scope of the invention, as illustrated by the accompanying

schematic sectional drawings, Figures 3, 4, 5, 6 and 6A, in which like reference numerals denote like parts.

Each of Figures 3-6 and 6A shows in schematic section
5 an assembly 101 incorporating both an electrode 102 and a
hermetically sealed operational amplifier integrated
circuit 103 connected as a signal processor so that it can
give an output (usually amplified and at relatively
low-impedance) corresponding to the signal potential
10 developed by the electrode in use. Any desired number of
wire connections 104 or other means of connections are
provided at one end of each assembly, to provide for
signal takeoff, power supply and any other function
corresponding to the nature of the particular circuitry,
15 which in itself forms no part of the invention.

Each assembly (other than Figure 6 and 6A) is based
on a laminar polymer sheet, (here pvc,) which serves as a
substrate 105.

20 Conductive tracks 106 are bonded to the substrate 105
by screen-printing a conductive-particle-pvc mixture, and
drying/hardening the result, and a hermetic sealing 107
ion-selective membrane coating 108 is applied in the case
25 of each assembly, all by the techniques already described
herein.

In the device of Figure 3, the electrode 102 is
formed by a part of the conductive track 106 and the
30 overlying membrane layer 108 which is applied over an end
part of the substrate 105 and conductive area not covered
by hermetic sealing 107.

In the device of Figure 4, the hermetic sealing layer
35 107 covers the whole of substrate 105 and the components
mounted on it. A further conductive layer 109 is applied

by similar screen-printing technique as before to part of the upper surface of sealing layer 107, and is conductively connected to track 102 by a previously-bored hole 110 filled with a matrix loaded with conductive particles, e.g. by a similar composition as is used to make the conductive layers. Membrane layer 108 is then applied to conductive track 109.

The device of Figure 5 is similar to that of Figure 4 except that the extra layer 109, and conductor-filled boring 110 are applied to substrate 105 instead of sealant layer 107, and membrane layer 108 is formed in an appropriate position to result in an electrode mounted on the opposite side of substrate 105 to the side on which the other components are mounted.

In a useful variant of the device of Figure 5, conductive tracks 106 and 109 are joined by their extension up to and around the edge of substrate 105 instead of the connection shown as in Figure 5, and the sealant layer 107 extends to cover the area in which they so join.

In the devices of Figures 6 and 6A, which represent a convenient simplification of the construction used in the devices of Figures 3-5, the packaging 103 (e.g. epoxy packaging) of a hermetically sealed operational amplifier integrated circuit or other appropriate semiconductor circuit or device itself forms the substrate on which a membrane electrode structure is fabricated. A conductive track 106 is bonded to the surface of the packaging 103 in contact with a suitable one of the connexion wires 104, and at least an electrode portion 102 of track 106 is overlain by a suitable membrane coating 108. If desired, a further overall hermetic sealing 107 can be applied, leaving a suitable number of electrical connexions and

active electrode areas clear to function. The order in which the hermetic packaging 107 and the membrane material 108 are applied is not critical so long as an effective seal is obtained. For the device of Figure 6A, it may be most practical to apply membrane 108 last. For these 5 embodiments in particular it is recommended to use (in the case of an epoxy packaging 103) a silver-particle-loaded conductive paint of a kind conventional in itself, if convenient such a paint based on epoxy material, and pvc 10 is suitable for application as the base component of a membrane material on top of such a conductive layer.

Devices similar to those of Figures 3-5 can be made on the basis of siliceous or ceramic substrates and glass 15 membranes, among other materials.

The examples of devices described and illustrated are robust selectively ion-sensitive electrodes with good resistance to degradation by the permeation of sample 20 liquids and components thereof, and are accessible to a flexible and convenient manufacturing process allowing the production of electrode systems with a variety of specificities.

It will be understood that many modifications and variations are applicable to the devices described herein. For example, a plural number of conductive electrodes can be applied to a planar substrate as in Example 3, and by suitable masking or other method of restricting the area 30 of application of layers, membrane layers can be applied to each conductive electrode, with the different membrane layers being either similar or different in composition, to give multiple specificity in a single electrode assembly. The upper edge of a planar electrode or 35 assembly of electrodes can carry a plurality of ohmic contact locations, at least one for each electrode, and

can be connected to an external circuit in any desired manner, e.g. by a snap-fitting connector or plug-and-socket edge connector.

5 It is also within the scope of this invention, to use
electrode systems as described herein, which have been
modified to form a layer of enzyme or other protein in
contact with the polymer membrane layers or other
10 non-conductive matrix membrane layers, especially the pvc
layers, to modify the action of the membrane and the
electrode in an analogous manner to the modification of
previous pvc membrane electrodes described by Ismail et
al., in *Analyst*, 109, (1984), pp 1205-1208.

15 Further details of the methods used to fabricate
particular examples of electrodes as described herein, and
details of tests carried out on electrodes so fabricated,
are shown in accompanying schematic drawings 7A - 7E.

20 Figure 7A shows in diagrammatic form the arrangements
used to screen-print the conductive flowable "inks"
comprising silver particles and hardenable polymer base
(e.g. as commercially obtainable for the purpose of
25 manufacturing hybrid electronic circuitry) on to
substrates as discussed herein. In Figure 7A, a
screen-printing frame 701 supports a gauze and mask 702
and is coated with ink 703 which is applied to the
substrate 704 at the open areas of mask 702 by the action
of a squeegee 705.

30 Figure 7B shows the chloride sensitivity (millivolts
versus $p[Cl^-]$ i.e. negative log activity) of a
screen-printed silver electrode made in this way and
anodised in 0.1M HCl with a Pt wire cathode for 300-1200
35 seconds at 0.85 mA/cm^2 .

Figure 7C plots the slopes of graphs like Figure 73 for a range of anodisation times (minutes).

Figure 7D shows the sensitivity (millivolts versus $p[Cl^-]$ negative log activity) for electrodes anodised for short times (30 seconds at current densities (for plots 1 to 5) of 0.85, 0.42, 0.21, 0.095, and 0.040 mA/cm² respectively).

It has been found that if the extent of anodisation is fixed in terms of charge per unit area (252 millicoulombs/cm²) then the electrode slope is within the range 57.1-57.2 mV/p[Cl⁻] for a wide range of reciprocally varying anodisation times and current densities (1200-150 seconds, 0.21-1.68 mA/cm²).

Figure 7E summarises the electrode sensitivities obtained for a range of anodisation charge densities (slope (mV/p[Cl⁻]) versus charge density (millicoulomb/cm²)).

These graphs indicate among other things the extent to which AgCl needs to be formed to give maximal sensitivity in the resulting electrodes.

It has been found that, provided the formation of AgCl is carried out to an adequate extent for maximal sensitivity, the consistency in the slope (sensitivity) amongst screen-printed anodised Ag/AgCl electrodes is comparable with that of good conventional wire electrodes (54.7-8 mV/p[Cl⁻] in comparison with 55.0-1 mV/p[Cl⁻]).

The several features described herein, including those illustrated in and by the drawings, can be used in any desired combinations and variations.

Claims

1. A composite electrode, comprising:
 - 5 a solid non-metallic substrate, (such as ceramic, glass, or epoxy resin,) and, bonded directly or indirectly to said substrate,
 - 10 a non-conducting matrix, incorporating particles which are accessible to the electrode surface and contain an insoluble metal salt (e.g. halide) in direct electrical contact with the metal corresponding to said salt, said metal being present
 - 15 either (i) in the form of metallic particles incorporated in a non-conducting matrix zone disposed so that said metal salt-containing particles are located between said metallic particles and said electrode surface, and/or (ii) a solid metallic
 - 20 surface in the form of an intermediate layer between said matrix and said substrate.
 2. A composite electrode according to claim 1, further comprising an electroactive membrane which overlies
 - 25 said matrix incorporating said metal halide-containing particles.
 3. A composite electrode according to claim 1 or 2, wherein the metal halide-containing particles are
 - 30 derived from a layer of non-conducting matrix incorporating metallic particles the surface of which layer has been treated to convert metal to metal halide.
 - 35 4. A composite electrode according to claim 1, 2 or 3, wherein the particle-containing matrix has been

formed by printing a layer of corresponding material in flowable form on to the solid substrate, and hardening the layer or allowing it to harden.

- 5 5. A composite electrode according to any of claims 1-4, wherein the substrate comprises plastics or ceramic material such as epoxy, polyvinylchloride, or alumina.
- 10 6. A composite electrode according to claims 1-5, wherein the particles in the matrix comprise silver and/or silver chloride-containing particles.
- 15 7. A composite electrode according to any of claims 1-6, wherein successively applied adjacent matrix layers are present on the substrate, including a layer containing metallic particles and a superficial layer containing insoluble metal-salt-containing particles.
- 20 8. A composite electrode according to any of claims 1-7, wherein a hermetic sealing layer is present over all conductive or electroactive parts of the electrode other than the sensitive surface intended to contact electrolyte.
- 25 9. An assembly comprising a composite electrode according to any of claims 1-8, wherein the metallic part of the composite electrode is functionally connected to a hermetically sealed (packaged) semiconductor device or integrated semiconductor circuit mounted on said solid non-metallic substrate.
- 30 10. An assembly according to claim 9, comprising an alumina or other ceramic substrate, or a pvc or other polymer substrate, on which there is mounted a hermetically encapsulated semiconductor device or
- 35

integrated circuit, with its connexions electrically bonded to the conductor(s) forming electrode(s) on the substrate, and the structure being further encapsulated with a hermetic sealing material applied by spraying, dip-coating, moulding or otherwise in manner known

5 per se, the sealing material being for example epoxy material or pvc or other polymer, to form an integral sealed assembly having a functionally exposed electrode area or areas not covered by the final encapsulation treatment.

11. An assembly according to claim 9, wherein said semiconductor device or integrated circuit is packaged in a non-metallic package which constitutes said substrate for said composite electrode.
12. A process for producing a composite electrode according to claim 1, which comprises (i) applying to a solid non-conducting substrate surface a flowable layer of a matrix material comprising particles that contain an insoluble metal and/or metal salt (e.g. halide), (ii) allowing the layer to harden and bond to the substrate surface, and (iii) (where the particles contain metal but did not already contain insoluble metal salt) forming insoluble metal salt corresponding to the metal of the particles either by treatment of the surface of said particles-containing matrix layer to form superficial insoluble metal salt thereon, or by applying a further bonded matrix layer of particles containing corresponding metal salt.
13. Composite electrodes and assemblies, and processes for producing them, based on layers of particle-containing matrices bonded to non-conducting substrates, characterised by any of the several

0186286

- 27 -

P3012

features of the accompanying description and drawings.

Fig. 1.

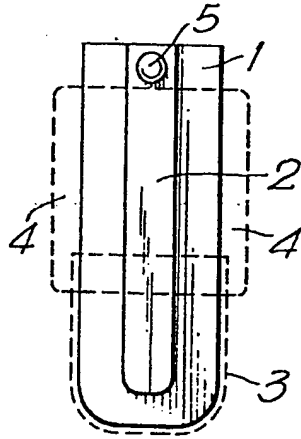

Fig. 2.

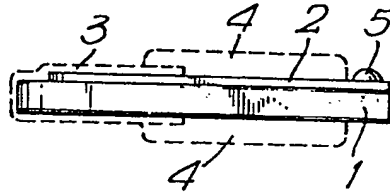

Fig. 3.

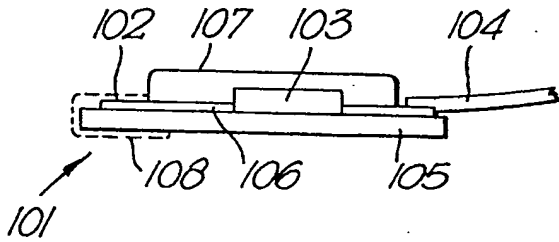

Fig. 6.

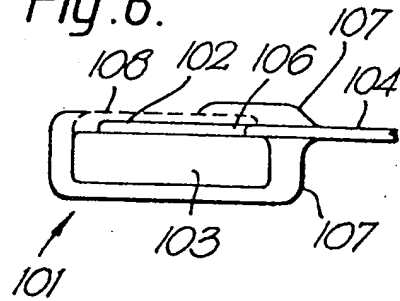

Fig. 4.

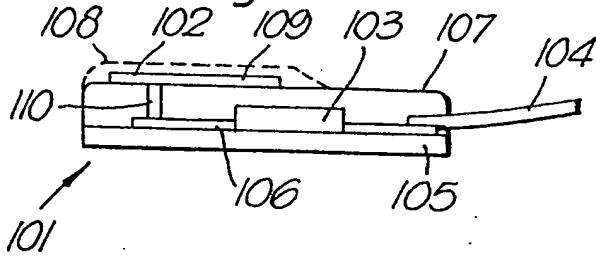

Fig. 6A.

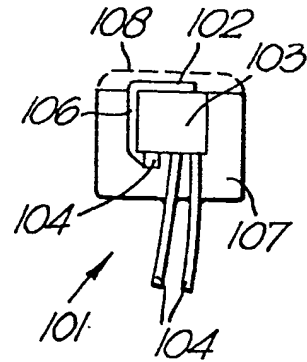

Fig. 5.

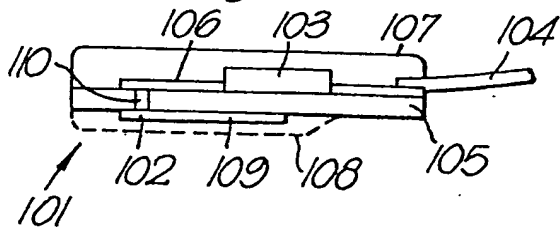
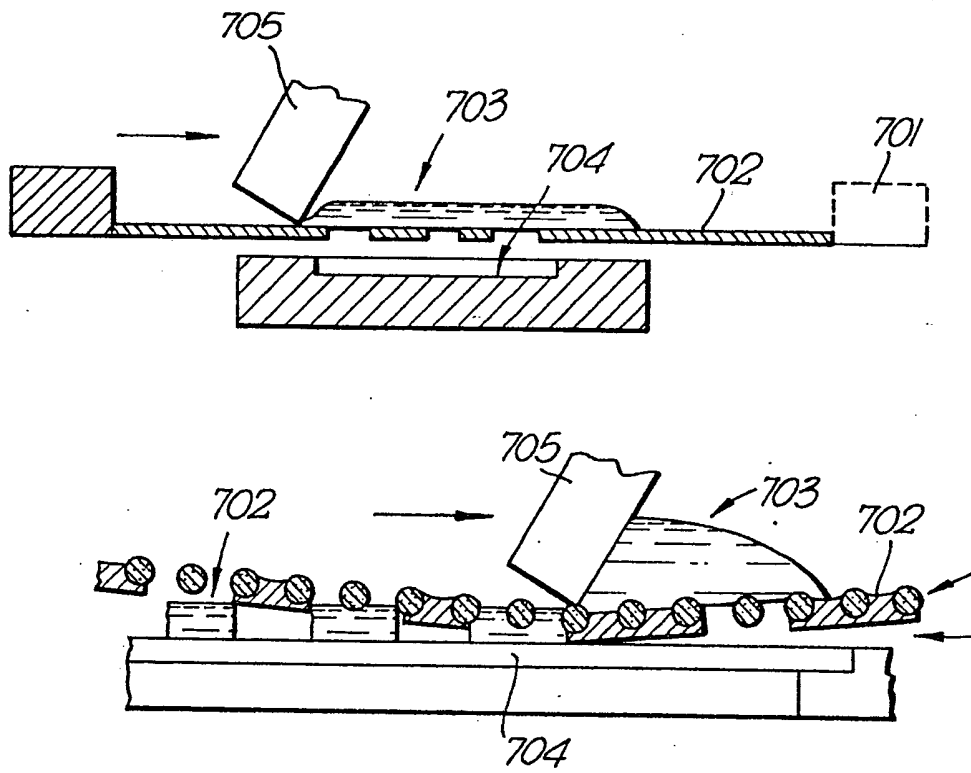

Fig. 7A.



3/4

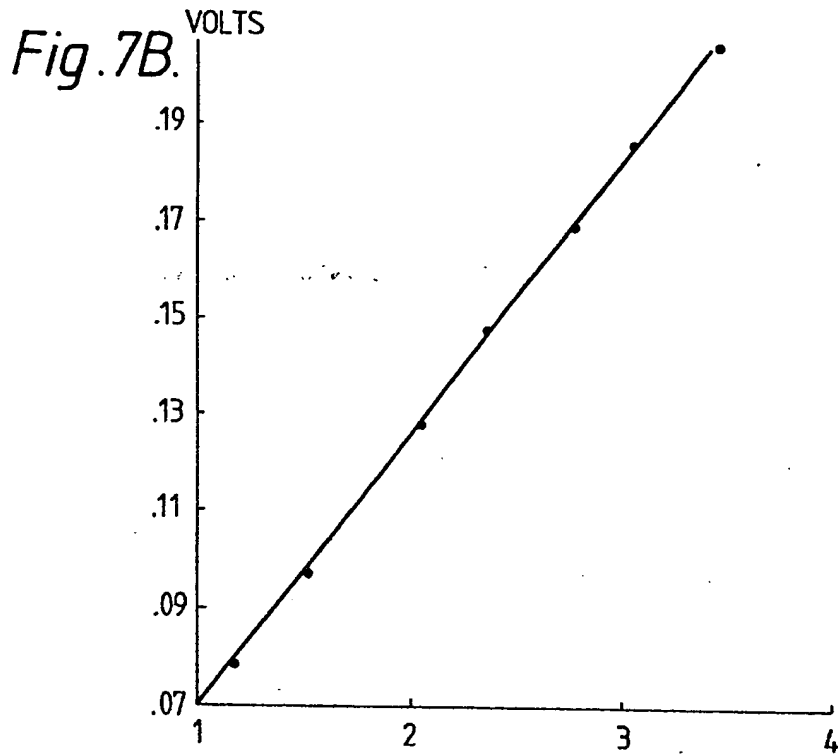
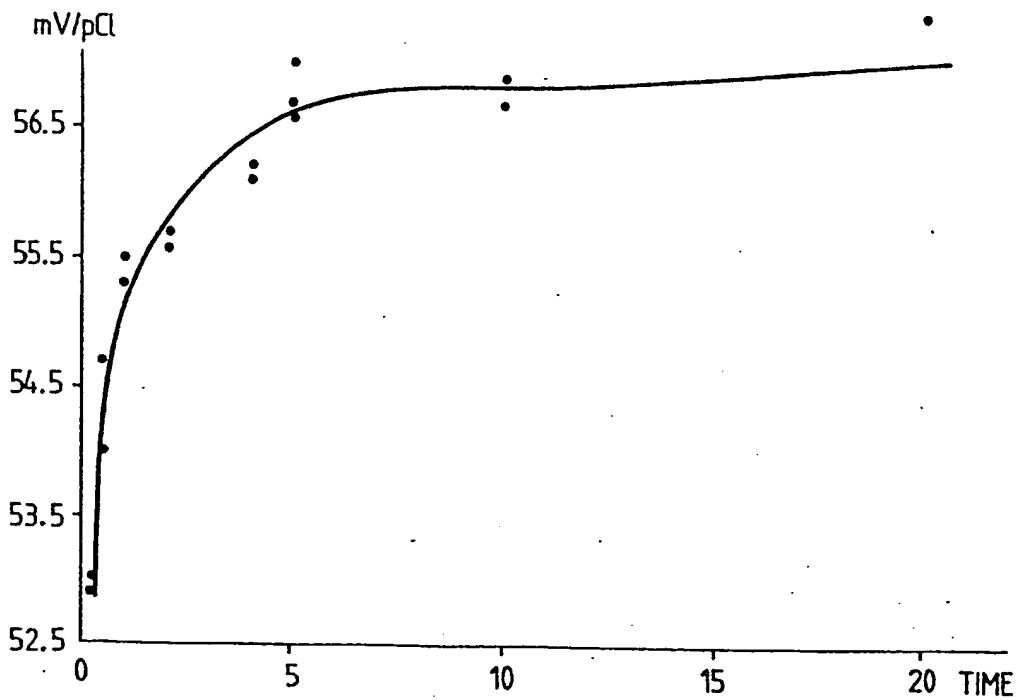

Fig. 7C.



4/4

0186286

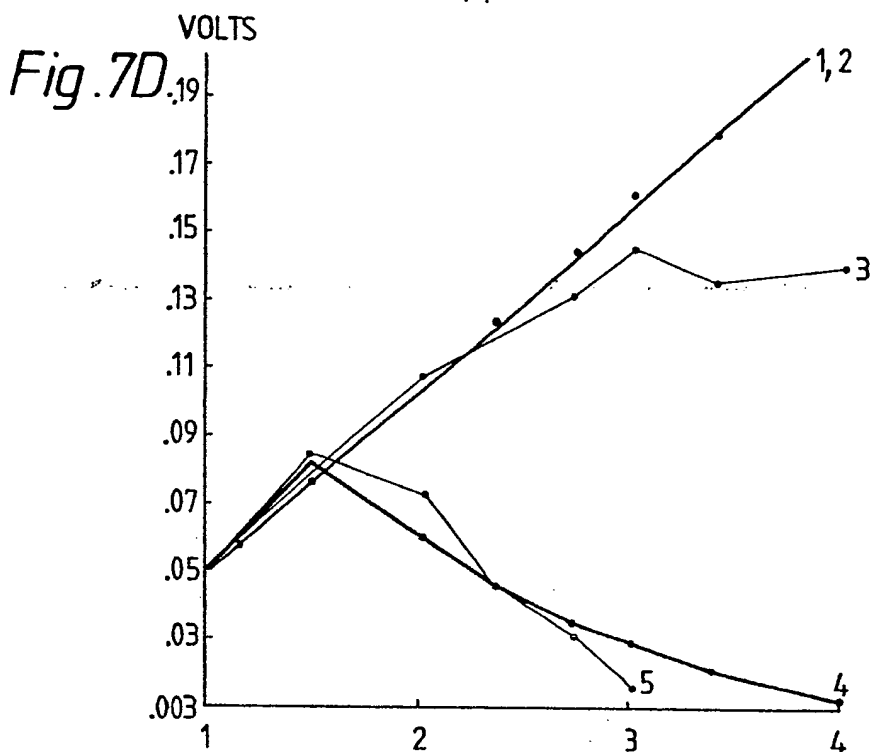
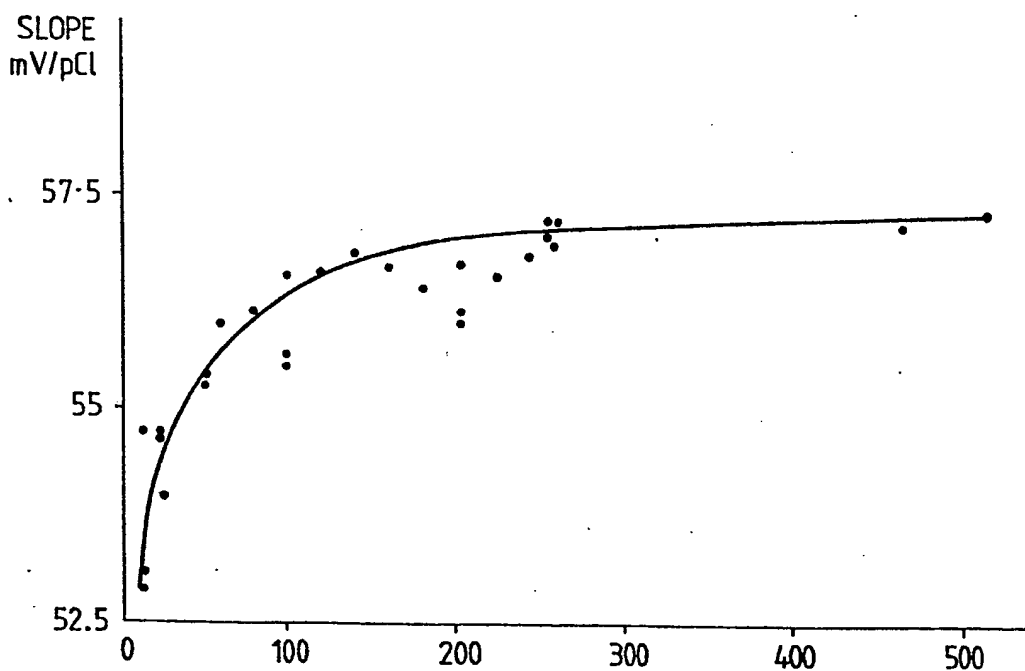

Fig. 7E.





European Patent
Office

EUROPEAN SEARCH REPORT

0186286
Application number

EP 85 30 7890

DOCUMENTS CONSIDERED TO BE RELEVANT			
Category	Citation of document with indication, where appropriate, of relevant passages	Relevant to claim	CLASSIFICATION OF THE APPLICATION (Int. Cl.4)
X, D	GB-A-2 021 772 (MAGYAR TODOMANYOS AKADEMIA) * abstract, page 1, lines 35-39, 46-50, 62-73 *	1, 6, 12	G 01 N 27/30 G 01 N 27/28 G 01 N 27/56
X	--- JOURNAL OF ELECTROCHEMICAL SOCIETY, vol. 126, no. 5, May 1979, pages 793-795, Princeton, US; T.A. FJELDLY et al. "Solid-State ion-selective electrodes with integrated electronics" * page 793, column 2, lines 21,22;29-33 *	8-11	
X, P	--- EP-A-0 125 560 (INTERNATIONAL BUSINESS MACHINES CORPORATION) * page 5, lines 4-7;18-19 *	1	
X	--- EP-A-0 030 503 (EASTMAN KODAK CO.) * abstract; page 3, lines 14-26;29,33-35; page 3, line 36 - page 4, line 2; page 4, lines 6-11; page 6, lines 31-36; figure *	1-6, 12	
	---		TECHNICAL FIELDS SEARCHED (Int. Cl.4)
			G 01 N 27/00
The present search report has been drawn up for all claims			
Place of search BERLIN		Date of completion of the search 10-01-1986	Examiner VINSOME R M
CATEGORY OF CITED DOCUMENTS			
X : particularly relevant if taken alone Y : particularly relevant if combined with another document of the same category A : technological background O : non-written disclosure P : intermediate document		T : theory or principle underlying the invention E : earlier patent document, but published on, or after the filing date D : document cited in the application L : document cited for other reasons & : member of the same patent family, corresponding document	

EPO Form 1503 03 82

DOCUMENTS CONSIDERED TO BE RELEVANT			Page 2
Category	Citation of document with indication, where appropriate, of relevant passages	Relevant to claim	CLASSIFICATION OF THE APPLICATION (Int. Cl.4)
X	EP-A-0 024 192 (EASTMAN KODAK CO.) * abstract; page 3, lines 14-15; page 4, line 13; page 4, line 35 - page 5, line 11; page 6, lines 29-31; page 8, lines 5-8; page 10, lines 24-28; page 12, line 39 - page 13, line 11 *	1-3,5,6,12	
X	EP-A-0 024 191 (EASTMAN KODAK CO.) * abstract; page 3, lines 16-25; page 4, line 8 - page 6, line 13; page 6, lines 30-32; page 7, lines 20-30; page 11, line 12 - page 12, line 1 *	1-3,5,6,12	
X	US-A-4 280 889 (L. SZONNTAGH) * abstract; claims *	1-6,12	
The present search report has been drawn up for all claims			TECHNICAL FIELDS SEARCHED (Int. Cl.4)
Place of search BERLIN		Date of completion of the search 10-01-1986	Examiner: VINSOME R M
CATEGORY OF CITED DOCUMENTS		T : theory or principle underlying the invention E : earlier patent document, but published on, or after the filing date D : document cited in the application L : document cited for other reasons & : member of the same patent family, corresponding document	
X : particularly relevant if taken alone Y : particularly relevant if combined with another document of the same category A : technological background O : non-written disclosure P : intermediate document			